

GlobalTech
AquaSonic[®]
Ultrasonic Cleaning Systems



AQS-7500

Fully Automatic Ultrasonic Stencil Cleaner

Closed-Loop Stencil Cleaning
with the RFS-25
Recirculation and Filtration System

JNJ Industries
800-554-9994
Specification/Data Sheet

AQS-7500

The AQS-7500 is a fully automatic ultrasonic stencil cleaner that is PLC controlled, with program storage capability for automatic setup and process control of 10 cleaning profiles. This state of the art system uses an integral pulse and sweep ultrasonic generation for optimal cleaning performance. All machine functions are controlled through the operator touch screen interface panel. An entire wash, rinse, and dry cycle can be run with the single touch of a button on the touch screen. The power pump to drain unit is integrated with a 5-micron recirculation filter, so wash tank fluids are filtered prior to going to drain. The recirculation pump can also be programmed to recirculate and filter the wash tank fluids automatically between cleaning cycles. There are individual solder traps for both the wash and rinse tanks that filter out solder and other particulates. The system comes standard with 4000 watt heaters for a controlled wash tank temperature range of 50° to 150° F. There is a side stencil rack that holds up to three stencils, and a SelectaWipe dispenser for holding a roll of JNJ SelectaWipes. The unique cleaning system features a two tank design that utilizes an ultrasonic wash tank and a high pressure spray chamber to clean stencils, wave solder pallets, misprinted boards, tools, and other accessories.



Two tank design features an immersion wash tank and a spray rinse chamber.

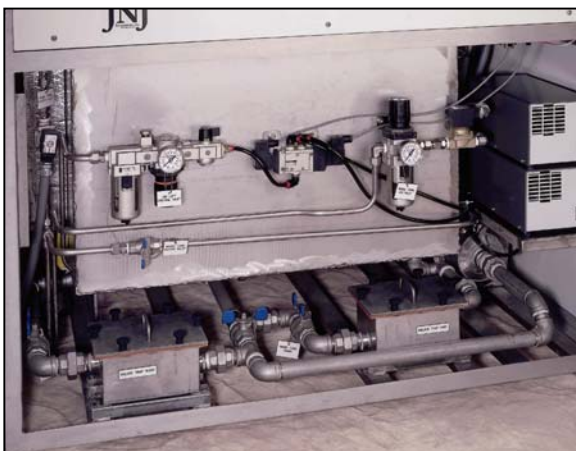

Stainless Steel construction of the chassis, tanks, and plumbing insures a long, trouble free life.

Ultrasonic Cleaning System

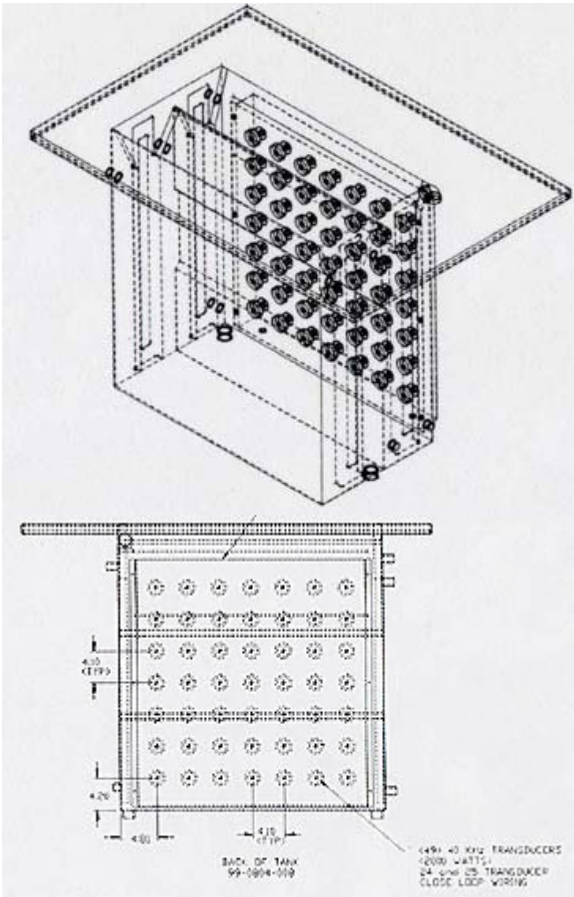

The drawing above shows JNJ's ultrasonic transducer panel layout. The matrix panel design ensures that the entire wash tank is active, experiencing full cavitation throughout the volume of the tank fluids. Systems with bottom mounted transducers or immersion transducers are prone to have dead zones without ultrasonic cavitation.

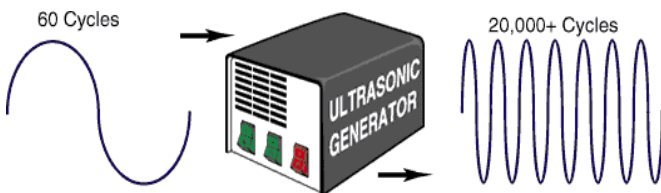

The ultrasonic generator converts electrical energy from the line which is typically alternating current at 50 or 60Hz to electrical energy at the ultrasonic frequency of 40KHz. Ultrasonic cavitation provides thorough cleaning over the entire surface of a stencil, as well as the inside walls of the apertures, reaching areas that spray cleaning machines cannot.

The AquaSonic cleaning system incorporates the intelligence and consistency of a computer controlled process, with state of the art ultrasonic cleaning power, and environmentally safe, yet effective cleaning chemistries. Our integral pulse and sweep generation provides optimum cleaning performance for cleaning BGA's, Micro BGA's, QFP's, and other ultra fine pitch component apertures. Spray cleaners simply will not clean the ultra fine pitch apertures found on today's stencils! Manual cleaning of stencils with these fine pitch devices can damage the apertures, rendering the stencil useless. Ultrasonic cleaning gently cleans these ultra fine pitch apertures from the inside, and will clean them completely, leaving even the finest pitch aperture free of all solder residue. The variable power control for the ultrasonics permits operators to reduce the percentage of output power, so that delicate products such as populated PC boards can be cleaned safely.

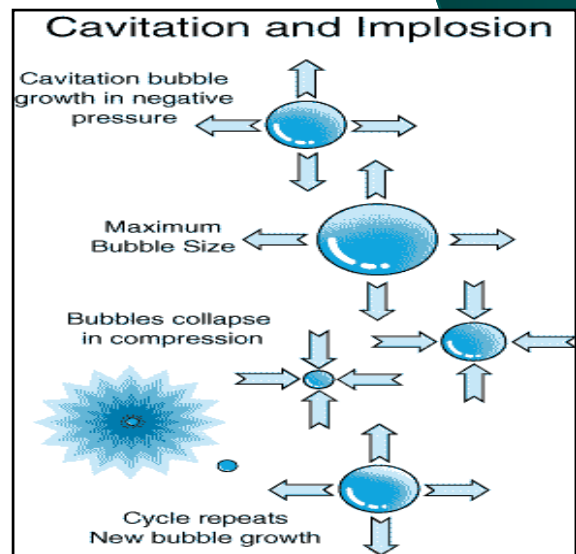

Ultrasonic Cleaning System

The utilization of pulse and sweep ultrasonic technology achieves optimum cleaning capability. The mix of technologies eliminates what is known as “standing wave”, which can lead to both hot spots where too much energy is applied, and to dead zones where not enough energy is applied.

- Electrical energy is supplied by the ultrasonic generator.
- This energy is applied to the piezoelectric elements in the transducer assembly, causing vibration.
- Vibrations are amplified and directed through the liquid.

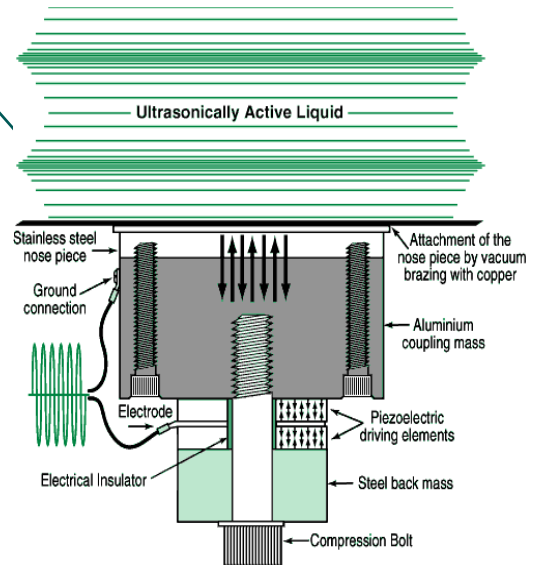

In **pulse** operation, the ultrasonic energy is turned on and off at a rate which may vary from once every several seconds to several hundred times per second.

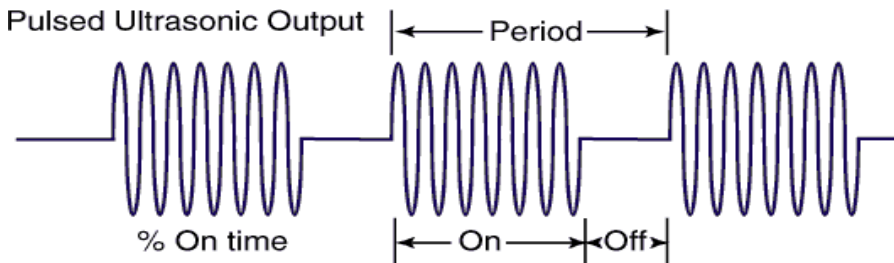

In **sweep** operation, the frequency of the output of the ultrasonic generator is modulated around a central frequency which may itself be adjustable.

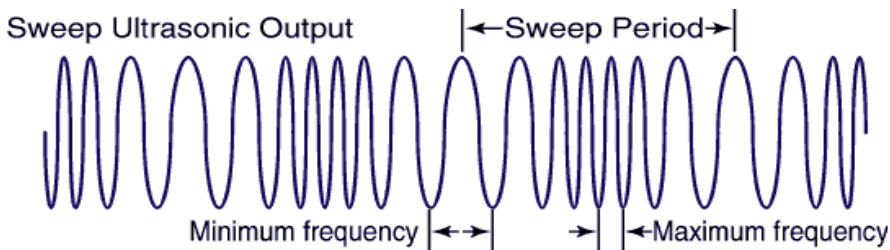

Closed-Loop Recirculation and Filtration

When connected to the RFS-25, the AQS-7500 provides closed-loop recirculation for both the wash tank fluids and the rinse water.

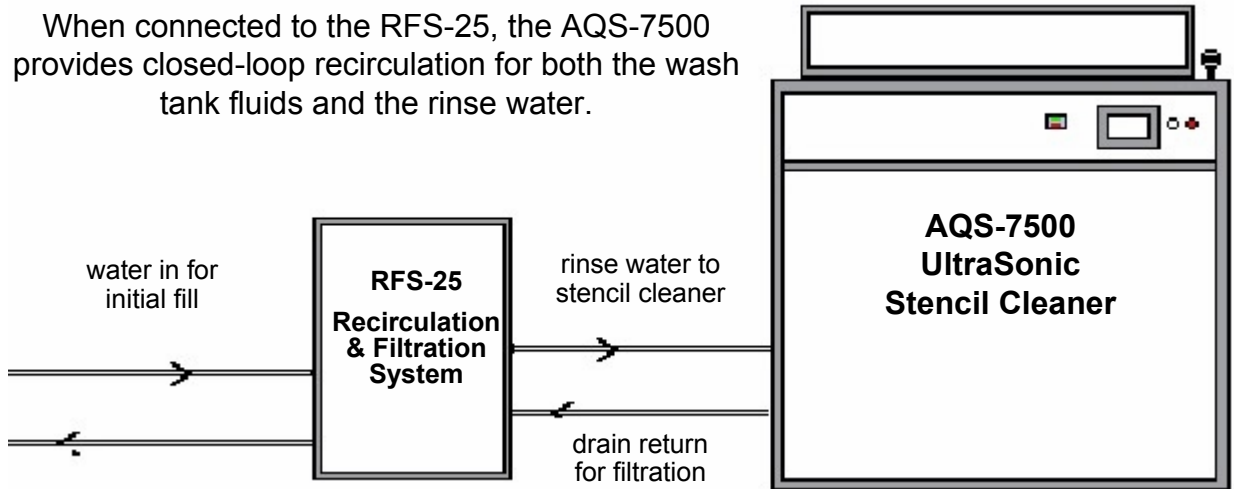

A three stage filtration system is combined with a recirculation pump to provide continuous filtration of the rinse water reservoir. Working with a simple handshaking signal, the RFS-25 is activated automatically during the automatic cycle of the AQS-7500, and can also be controlled manually, whenever rinse water is required. This closed-loop system provides up to six months or more of rinse water utilization between changes.

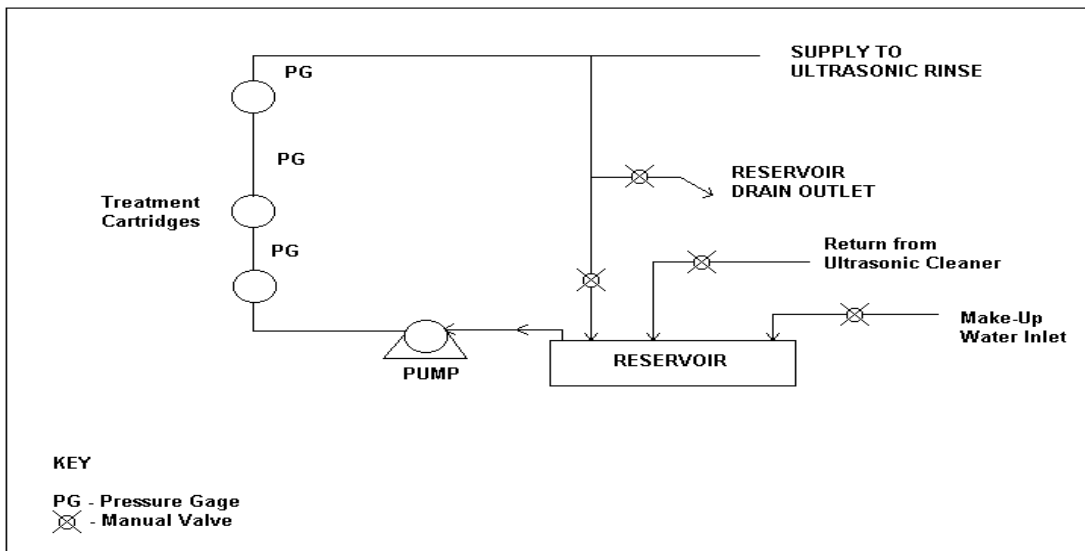

detailed plumbing diagram of JNJ's closed-loop system

Recirculate vs. Evaporate

- The RFS-25 runs for only a few minutes at a time, and uses a low amperage pump.
- Operating efficiency remains consistent.
- The RFS-25 requires no venting stacks, or any other special installation hardware.
- Closed loop operation means no VOC emissions.
- The RFS-25 costs under \$10K and plugs into a common outlet with no special requirements. Low cost filter changes once every three months.
- When the rinse water gets loaded with chemistry it can be transferred to the wash tank of the ultrasonic cleaner for further use.
- Evaporators are energy hogs – requiring high amperage to boil water, and need to run for hours at a time.
- Evaporators become less efficient as the sludge builds up.
- Evaporators are expensive to install, requiring ventilation stacks .
- Evaporator’s venting increases VOC emissions.
- Evaporators are expensive to buy, expensive to install, and expensive to operate and maintain.
- Evaporators leave behind a sludge that has to be cleaned out and processed as solid hazardous waste.

Evaporation technology is not environmentally friendly, as it requires a great deal of electrical energy to operate, leaves behind solid waste, and emits VOCs through vent stacks. Recirculation and filtration is the most environmentally friendly way of handling an aqueous waste stream.

RFS-25 Specifications

- Overall Dimensions.....L: 36" W: 24" H: 36"
- Capacity25 Gallons of Rinse Water
- Output.....6 GPM @ 56PSI
- Voltage.....110 VAC, Single Phase
- Amperage.....0.5 HP/9.8A/4.9A Full Load
- Construction.....Stainless Steel
- Filtration: 3 Stage
 - 10-micron Polypropylene
 - 10-micron Activated Carbon Composite
 - 5-micron Polypropylene
- Plumbing Connections:
 - 1" NPTF - Drain
 - ½" NPTF - Water Inlet
 - ½" NPTF - Water Output to Stencil Cleaner
- Electrical Connection:
 - 1 @ 115 VAC , 10 Amps, 1Ø
- Air Connection:
 - None required

System Footprint

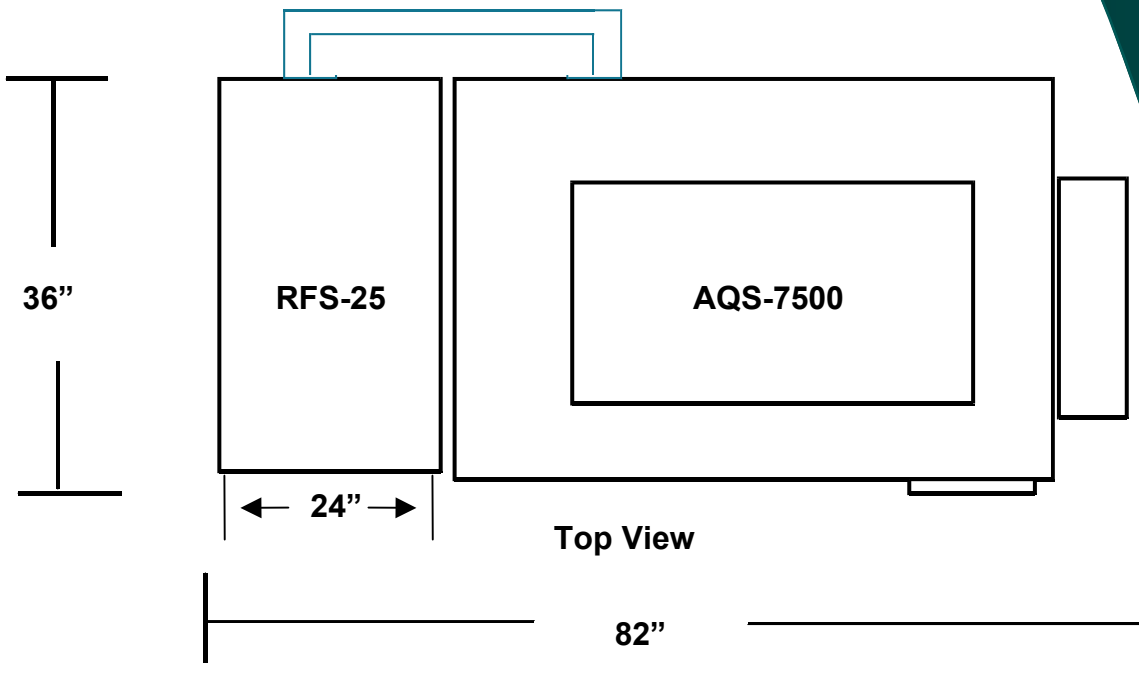

AQS-7500 Specifications

- Overall Dimensions..... .53" L x 36" D x 48" H
- Wash Tank Dimensions.....34" x 8" x 36"
-34" liquid level
- Heated Wash..... 4000 Watts, 50 –150° F
- Rinse Tank Dimensions.....34" x 10" x 36"
- Maximum Stencil Size.....31" x 34"
- System Capacity.....40 Gallons
- Power Requirements.....230 VAC, 1Ø, 50/60 Hz
 - -20 amps without heat
 - -35 with optional heaters
- Air Requirements..... 80 PSI@ 25 CFM*
 - * CFM rating is based on air knife consumption
- Cleaning Power.....2000 Watts
- Transducer Type..... Piezoelectric
 - -transducers are attached to sides of wash tank
- Ultrasonic Generation.....Integral Pulse & Sweep
- Filtration.....5-micron
- Solder Trap.....For Wash and Rinse Tank Fluids
 - -with SS mesh filters for catching gross particulates
- Drainage.....**Powered Pump To Drain Unit**
- Sensor Protection.....For Low Liquid Level
- Water Requirements.....40 PSI (soft or DI water)
- Average Cycle Time-Wash.....2 Minutes
- Average Cycle Time-Rinse.....1 Minute
- Plumbing Material..... Stainless Steel
- Tank Material.....Stainless Steel - SS-316L
- Electrical Connection:
 - 1) 208 VAC, 1Ø, Rated a @ 45 Amps
- Plumbing Connections:
 - Drain: 1" NPTF
 - Water Inlet: ½" NPTF
 - Air Inlets: ½" NPTF, Qty. 2
- Air Connections:
 - ½" NPTF Rated @ 10 CFM
 - ½" NPTF Rated @ 25 CFM (for air knives)



The AQS-7500 is equipped with a solder trap, a 5-micron filter, and a recirculation pump for the wash tank which are used to keep wash tank fluids free of contamination.



Digital temperature control for maintaining proper wash tank temperatures.

AQS-7500 Features

- **49 Ultrasonic Transducers**
 - 2000 Watts of cleaning power
 - Piezoelectric type
 - Wired in parallel
 - Lifetime warranty
- **Generator**
 - Neptune™ Series featuring
 - Integral pulse and sweep
- **40 Rinse Spray Nozzles**
 - 20 on each side
 - Adjustable pressure valve
 - Fixed angle
 - Removable for service
- **3 Stage System**
 - Wash
 - Rinse
 - Air dry in rinse chamber
- **Cover**
 - Automatic lift
 - Automatic tank transfer
 - Automatic lower
- **Heated Wash**
 - 4000 Watts
 - 50° F to 150° F
- **Tank Capacity**
 - 40 gallons
- **Air Knives**
 - One on each side
 - Air curtain
 - Regulated and filtered
 - Adjustable angle
- **PLC Control**
 - Store 10 programs
 - Automatic operation
 - Automatic setup
- **Shipping Weight**
 - 1200 lbs.

Fully Automatic Operations

Programmable Features

- Power and wash time
- Rinse, dwell, and dry times
- Dry during lift
- Temperature settings are stored, but must be manually set on heater control unit
- Programs are saved to PLC for future cycles
- Preventative Maintenance (PM) variables are saved to PLC
- Setup and PM are password protected
- Input & Output status can be monitored on the touch screen
- Fully automatic operation at the touch of a button

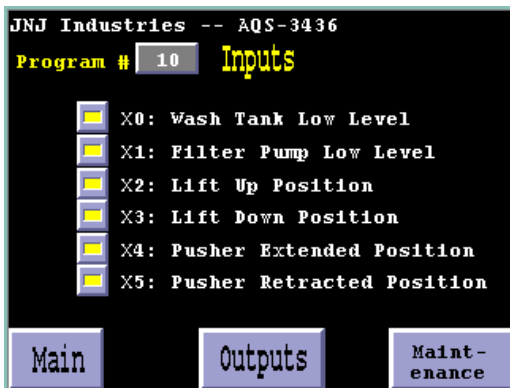

Input Screen



PM Screen

Interactive maintenance screens alert operators when it is time for preventative maintenance schedules and in the event of an alarm condition.

Fully Automatic Sequence

- Load stencil in to the stencil basket
- Press “Start Wash” on touch screen
 - Stencil is lowered, wash cycle starts and runs for programmed cycle time
 - Stencil is raised at end of cycle
 - Stencil is transferred to the rinse tank
 - Stencil is lowered, and rinse cycle starts and runs for programmed cycle time
 - Rinse turns off, dwell cycle starts and times out
 - Air knives turn on and run for programmed cycle time, then stencil automatically raises
- Cycle complete, operator removes stencil
- All functions can also be controlled manually through the touch screen, as seen below

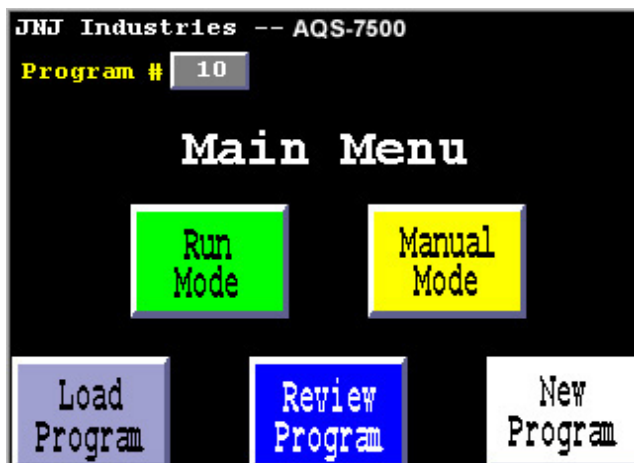

Automatically load program parameters from stored files.

AQS-7500 Reference Chart

Feature	Benefit	Details
Pulse & Sweep Ultrasonics	Improves cleaning capabilities and eliminates damage to delicate components.	Eliminates dead spots where standing wave damage can occur.
Piezoelectric Transducers	Temperature is stable - handles changes in frequency smoothly.	Controlled test chamber study has been conducted using extreme hot and cold temperature changes, proving no interference with transducers and systems function.
2000 Watts of Ultrasonic Power	Shortens cleaning times to 1 to 2 minutes. 100% cleaning of apertures. The variable power control permits the operators to reduce the percentage of output power, so that delicate products can be cleaned safely.	800 watts more than competitive ultrasonic cleaners in this class - out performs any spray cleaner for cleaning fine pitch apertures.
Automatic Lift, Lower & Transfer	Hands free washing, rinsing and drying. One button operation!	Automatic stencil lift, lower and tank transfer system allows for one button operation through operator interface panel.
5-micron Filtration System	Increases bath life - improves cleaning effectiveness of aqueous chemistries.	Filtration removes contaminants that can reduce cleaning effectiveness and shorten the life of the chemistry.
Recirculation Pump	Recirculates wash tank fluids through the 5-micron filter - allows for easy pump to drain of wash tank fluids.	Stainless steel pump is used to recirculate and filter or remove fluids from the wash tank -pump is controlled by the touch screen interface panel.
Programmable Logic Control (PLC)	Stores up to ten cleaning profiles. Program and maintenance parameters are password protected.	Allows results from cleaning tests to be stored and then easily accessed. Prevents over cleaning due to operator error.
One Touch Operation	Operators can initiate total machine and process control for every cleaning cycle by the single press of a button on the touch screen.	Program storage does not require operators to be present during the cleaning cycle.
Preventative Maintenance	Preventative maintenance variables are saved on the PLC.	Interactive maintenance screens alert operators when it is time for preventative maintenance schedules and in the event of an alarm condition.
Heated Wash Tank	4000 watts of heating power at precise temperatures aids in cleaning hard to remove contaminants.	Heat provides additional cleaning power when cleaning epoxies and adhesives - heating elements are controlled through the digital control interface thermostat.
Dual Solder Trap Filtration	Eliminates gross particulate contamination of the wash and rinse tank fluids - dual collection of solid waste for disposal or reclamation.	Three chamber, waterfall design is a significant improvement over competitor's designs - solder traps contain a stainless steel mesh filter that captures gross particulates.

Options and Accessories

- **AQS-7500**

- Auto Fill Sensor
- EC Wiring
- Alternate Power Source
- Light Signal Tower
- Tank Inserts
- Shipping Crate
- Spare Parts Basket
- Board Holder Rack
- Spare Filters
 - Stainless Steel Solder Trap Filter
 - 5-micron Wash Tank Filter
- AquaSonic Aqueous Chemistry - SMA

- **RFS-25**

- Spare Filters
 - 10-micron Polypropylene
 - 10-micron Activated Carbon Composite
 - 5-micron Polypropylene

To receive additional information, contact JNJ by e-mail at equipsales@jnj-industries.com, or call us at 800-554-9994.

Visit us at www.jnjultrasonics.com.