

SMARTROLL®

CUSTOM SPECIFICATIONS/CUSTOMER

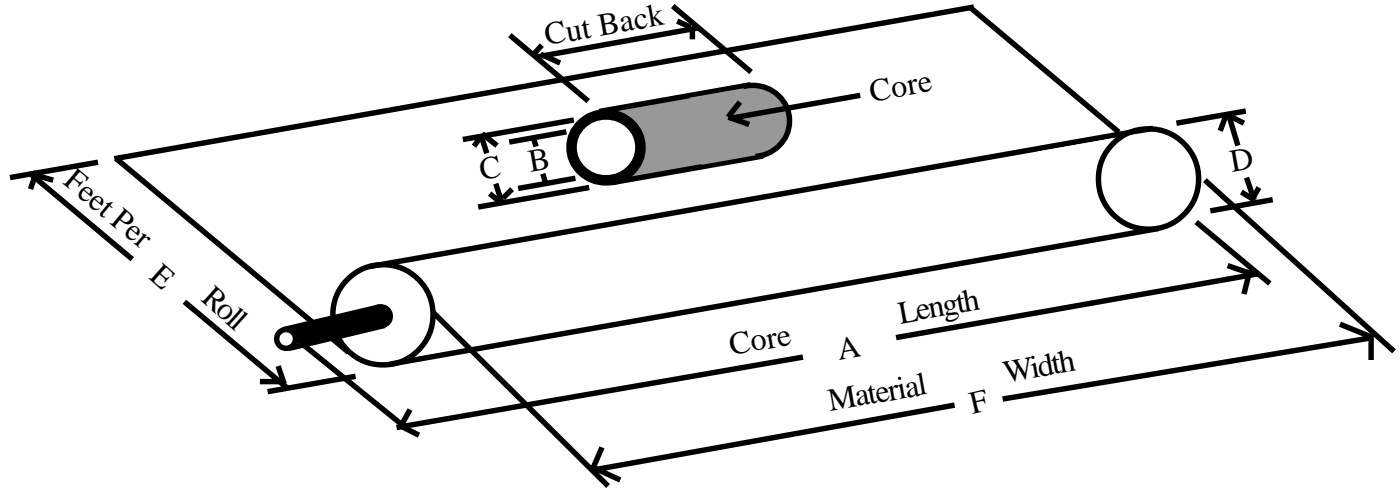

NAME: _____ DATE: _____

COMPANY: _____

ADDRESS: _____

CITY: _____ STATE: _____ ZIP CODE: _____

PHONE #: _____ FAX #: _____

SCREEN/STENCIL PRINTER: _____

FOR VACUUM SYSTEMS? YES: NO:

EXPECTED MONTHLY USAGE: _____

CORE DIMENSIONS:

CORE LENGTH: "A": _____ (INCHES)

CORE I.D.: "B": _____ (INCHES)

CORE O.D.: "C": _____ (INCHES)

NOTCHES IN CORE: YES: NO:

SPARE CORE: YES: NO:

CORE MATERIAL:

PAPER: PLASTIC: OTHER:

MATERIAL DIMENSIONS:

MAXIMUM ROLL O.D.: "D": _____ (INCHES)

*FEET PER ROLL: "E": _____ (FEET)

*FEET PER ROLL TOLERANCE IS +/- 10%

MATERIAL WIDTH: "F": _____ (INCHES)

TOTAL MATERIAL CUT BACK: _____ (INCHES)

IS ROLL CENTERED ON CORE: YES: NO:

CUT BACK: RIGHT: _____ (INCHES)

LEFT: _____ (INCHES)

MATERIAL SENSOR WINDOW: YES: NO:

ADDITIONAL INFORMATION:

MATERIAL SPECIFICATIONS:

CUSTOMER SIGNATURE: _____

FAX BACK TO: **JNJ INDUSTRIES, INC.** - FAX # (508) 553-9973 OR CALL # (800) 554-9994 OR (508) 553-0529

WEB SITE: WWW.JNJ-INDUSTRIES.COM

E MAIL: SALES@JNJ-INDUSTRIES.COM